

**vtech**<sup>®</sup>  
Baby

User's Manual

# Too-Too Drivers

## Deluxe Track Set

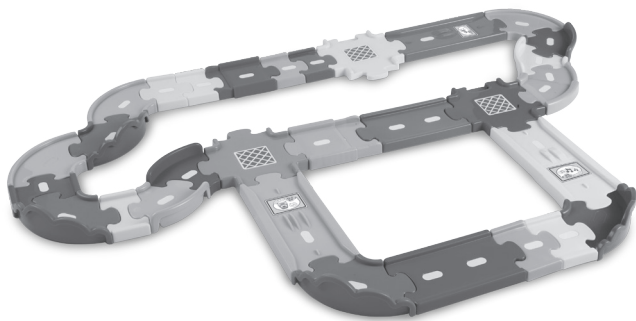

© 2013 VTech  
Printed in China

91-002851-000 ©

VTech understands that a child's needs and abilities change as they grow and with that in mind we develop our toys to teach and entertain at just the right level...

### **vtech** Baby

Toys that will stimulate their interest in different textures, sounds and colours

#### I am...

...responding to colours, sounds and textures

...understanding cause and effect

...learning to touch, reach, grasp, sit-up, crawl and toddle

Birth-36 months



### **Pre-School**

Interactive toys to develop their imagination and encourage language development

#### I want...

...to get ready for school by starting to learn the alphabet and counting

...my learning to be as fun, easy and exciting as can be

...to show my creativity with drawing and music so my whole brain develops

3-6 years



### **Electronic Learning Computers**

Cool, aspirational and inspiring computers for curriculum related learning

#### I need...

...challenging activities that can keep pace with my growing mind

...intelligent technology that adapts to my level of learning

...National Curriculum based content to support what I'm learning at school

4-10 years



To learn more about this and other VTech® products, visit [www.vtechuk.com](http://www.vtechuk.com)

# INTRODUCTION

Thank you for purchasing the **VTech® Toot-Toot Drivers® Deluxe Track Set** learning toy!

Possibilities are endless with the **Toot-Toot Drivers® Deluxe Track Set** by **VTech®**! Help your child to explore their creativity and discover countless track configurations. With 30 interchangeable track pieces, they can create an exciting race track or connect to other playsets. Each piece is designed for little hands so they'll develop their fine motor skills while connecting the tracks and playsets to create their own **Toot-Toot Drivers®** world. It's playtime with miles of learning!

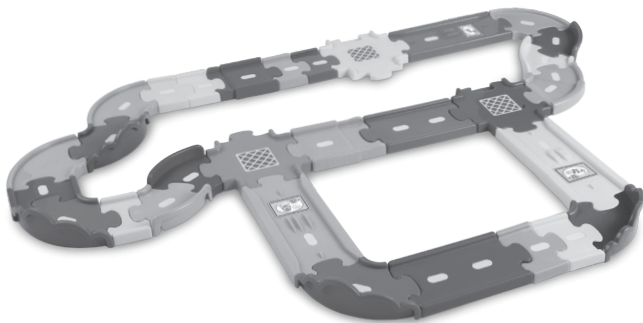

## INCLUDED IN THIS PACKAGE

- One VTech® Toot-Toot Drivers® Deluxe Track Set learning toy
- One instruction manual
- One sheet of labels

**WARNING:** All packing materials, such as tape, plastic sheets, packaging locks and tags are not part of this toy, and should be discarded for your child's safety.

**NOTE:** Please keep this user's manual as it contains important information.

**Includes 30 track pieces of 12 different types:**



3 SmartPoint™ tracks



2 straight tracks



1 female connector track



1 male connector track



6 male/female connector tracks



4 90-degree tracks, female



3 90-degree tracks,  
male



2 60-degree tracks,  
female



2 60-degree tracks,  
male

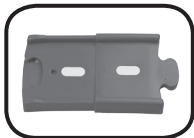

2 adjustable straight  
tracks



2 adjustable curve  
tracks



3 cross tracks

**Please stick the labels to the tracks securely, as indicated below:**

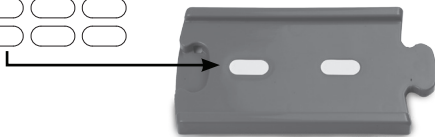
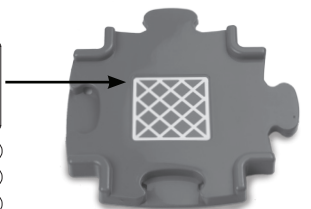
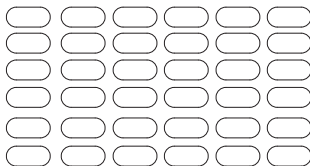
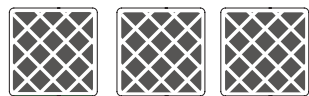

# TROUBLESHOOTING

If for some reason the program/activity stops working or malfunctions, please follow these steps:

1. Please turn the unit OFF.
2. Interrupt the power supply by removing the batteries.
3. Let the unit stand for a few minutes, then replace the batteries.
4. Turn the unit ON. The unit should now be ready to play again.
5. If the product still does not work, replace with a new set of batteries.

If the problem persists, please call our Consumer Services Department on 01235 546810 (from UK) or +44 1235 546810 (outside UK) and a service representative will be happy to help you.

## IMPORTANT NOTE:

Creating and developing VTech® products is accompanied by a responsibility that we take very seriously. We make every effort to ensure the accuracy of the information which forms the value of our products. However, errors sometimes can occur. It is important for you to know that we stand behind our products and encourage you to call our Consumer Services Department on 01235 546810 (from UK) or +44 1235 546810 (outside UK) with any problems and/or suggestions that you might have. A service representative will be happy to help you.



## PRODUCT WARRANTY



Thank you for choosing this quality product from VTech. We hope it will bring many hours of entertainment, imaginative play and learning.

1. The product detailed above is covered by a one year warranty from the date of purchase, against any defects in materials or workmanship.
2. The product may be returned to the place of purchase. Alternatively the product can be returned to VTech Electronics Europe plc (see address below), with proof of purchase, without proof of purchase no replacement will be provided.
3. VTech Electronics Europe plc will examine the product and if it is found to be defective due to faulty materials or workmanship, will replace the product at their discretion.
4. If the product covered by this warranty is damaged due to misuse, modification or unauthorised repair, or because of faulty batteries, battery discharge or incorrect electrical connections, then this warranty becomes void.
5. This warranty is personal to the original purchaser and is not transferable.
6. Breakages to the LCD screen are not covered by the warranty.
7. Returns to VTech Electronics Europe plc should include a cheque or postal order for £1.50 towards the cost of return postage and packaging.
8. Products returned to VTech Electronics Europe plc, should be addressed as follows and packed carefully to avoid damage in transit (Please do not include batteries or adaptor).  
Please include details of the fault together with your name and address.

VTech Electronics Europe plc, c/o Tablogix Limited, 200 Milton Park, Abingdon, Oxon OX14 4TA

THIS WARRANTY IS OFFERED AS AN EXTRA BENEFIT AND DOES NOT AFFECT CONSUMERS' STATUTORY RIGHTS.

This warranty is valid for the UK and Eire only. For products purchased outside the UK and Eire, please contact your local distributor or place of purchase.

